



## ZXU1 Mixing Loop Control - Single Zone *Self-Contained Interoperable Controller Model UCP-1*

SUPERSEDES: September 23, 2010

EFFECTIVE: November 17, 2010

### Table of Contents

ZXU1 .....	3	Specifications .....	13
Overview .....	3	Electrical .....	13
Features .....	3	Mechanical .....	13
Purpose of This Guide .....	3	Application Description .....	15
Representations and Warranties .....	4	Application Examples .....	16
Applicable Documentation .....	4	Sequence of Operation .....	18
Installation Guide .....	4	Outdoor Temperature Influence .....	18
Precautions .....	4	Setpoint Calculation .....	18
General .....	4	Boiler Protection .....	21
Static Electricity .....	5	Demand .....	22
Location .....	5	Valve Output .....	22
FCC Compliance .....	5	Digital Outputs .....	22
Before Installing .....	5	Standalone Operation .....	23
About this Document .....	5	Networking .....	23
Inspecting the Equipment .....	5	Controller Identification .....	24
What is Not Included with this Equipment .....	5	Inputs .....	24
Equipment Location .....	5	Outputs .....	25
Selecting a Power Source .....	6	Configuration .....	25
Installation .....	6	Alarms .....	28
Mounting the Device .....	6	Troubleshooting .....	30
Routing Cabling to the Device .....	7	Diagnostic LEDs .....	30
Grounding the Device .....	8	Troubleshooting Tips .....	31
Wiring Information .....	8		
Connecting Input Devices .....	11		
Connecting Output Devices .....	11		
Other Connections .....	12		

**THIS PAGE LEFT BLANK INTENTIONALLY**

# ZXU1

The iWorX® ZXU1 is a stand-alone microprocessor-based controller for one injection loop.

## Overview

The ZXU1 provides injection mixing for one loop. The loop has a Supply and a Return Temperature and can be configured separately. Outdoor Air Temperature, Radiant Slab Temperature and Zone Temperature are also provided.

A Boiler Enable and a Primary Pump signal are provided if the loop has a demand. Demand can come from several sources.

Demands can be configured and processed as a heating or cooling demand.

It is assumed that all the boiler operations are taken care of elsewhere, possibly coupled with a BLM controller.

The iWorX® controller is based on the LONWORKS® networking technology. The controller can be networked to a higher-level control system for monitoring and control applications.

## Features

- Heat/Cool control selectable
- Heat Demand and Cool Demand inputs are provided
- Temperature alarms
- Modulating mixing output with adjustable min and max settings from 0-10V
- Loop has a separate Supply Temperature, Return Temperature, Radiant Slab Temperature and Pump signal
- Advanced Outdoor Air drybulb calculation
- Room Temperature for zone control
- Snowmelt mode with extended features
- Heat Demand and Cool Demand outputs provided
- Standalone configuration
- Outdoor Air Temperature for standalone mode
- Boiler Enable signal and Primary Pump signal available
- Boiler Protection
- LONWORKS interface to building automation systems.
- Automatic configuration with the iWorX® Local Control Interface (LCI)

## PURPOSE OF THIS GUIDE

The *iWorX ZXU1* provides application information for the ZXU1 Controller.

The reader should understand basic Radiant concepts, intelligent environmental control automation, and basic LONWORKS networking and communications. This Application Manual is written for:

- Users who engineer control logic
- Users who set up hardware configurations
- Users who change hardware or control logic
- Technicians and field engineers

## REPRESENTATIONS AND WARRANTIES

This Document is subject to change from time to time at the sole discretion of Taco Electronic Solutions, Inc. All updates to the Document are available at [www.taco-hvac.com](http://www.taco-hvac.com). When installing this product, it is the reader's responsibility to ensure that the latest version of the Document is being used.

The iWorX® ZXU1 shall only be used for the applications identified in the product specifications and for no other purposes. For example, the iWorX® ZXU1 is not intended for use to support fire suppression systems, life support systems, critical care applications, commercial aviation, nuclear facilities or any other applications where product failure could lead to injury to person, loss of life, or catastrophic property damage and should not be used for such purposes.

Taco Electronic Solutions, Inc. will not be responsible for any product or part not installed or operated in conformity with the Document and instructions or which has been subject to accident, disaster, neglect, misuse, misapplication, inadequate operating environment, repair, attempted repair, modification or alteration, or other abuse. For further information, please refer to the last page of this Document for the company's Limited Warranty Statement, which is also issued with the product or available at [www.taco-hvac.com](http://www.taco-hvac.com).

## APPLICABLE DOCUMENTATION

Description	Audience	Purpose
<i>iWorX® LC/2 Application Guide</i> , Document No. 505-002	<ul style="list-style-type: none"> <li>– Application Engineers</li> <li>– Installers</li> <li>– Service Personnel</li> <li>– Start-up Technicians</li> <li>– End user</li> </ul>	Provides instructions for setting up and using the iWorX® Local Control Interface.
<i>iWorX® LC/2 Quick Start</i> , Document No. 505-002a	<ul style="list-style-type: none"> <li>– Application Engineers</li> <li>– Installers</li> <li>– Service Personnel</li> <li>– Start-up Technicians</li> <li>– End user</li> </ul>	Provides instructions for setting up and using the iWorX® Local Control Interface.
<a href="http://iWorxWizard.taco-hvac.com">http://iWorxWizard.taco-hvac.com</a>	<ul style="list-style-type: none"> <li>– Application Engineers</li> <li>– Wholesalers</li> <li>– Contractors</li> </ul>	An on-line configuration and submittal package generator based on user input. Automatically generates bill of materials, sequence of operations, flow diagrams, wiring diagrams, points and specifications.
Additional Documentation	<i>LonWorks FTT-10A Free Topology Transceiver User's Guide</i> , published by Echelon Corporation. It provides specifications and user instructions for the FTT-10A Free Topology Transceiver. See also: <a href="http://www.echelon.com/support/documentation/manuals/transceivers">www.echelon.com/support/documentation/manuals/transceivers</a> .	

## INSTALLATION GUIDE

### Precautions

#### General



This symbol is intended to alert the user to the presence of important installation and maintenance (servicing) instructions in the literature accompanying the equipment.



**WARNING:** Electrical shock hazard. Disconnect **ALL** power sources when installing or servicing this equipment to prevent electrical shock or equipment damage.

Make all wiring connections in accordance with these instructions and in accordance with pertinent national and local electrical codes. Use only copper conductors.

## Static Electricity

Static charges produce voltages that can damage this equipment. Follow these static electricity precautions when handling this equipment.

- Work in a static free area.
- Touch a known, securely grounded object to discharge any charge you may have accumulated.
- Use a wrist strap when handling printed circuit boards. The strap must be secured to earth ground.

## Location

Avoid locations where corrosive fumes, excessive moisture, vibration or explosive vapors are present.

Avoid electrical noise interference. Do not install near large contactors, electrical machinery, or welding equipment.

This equipment is suitable for indoor or outdoor use. Preferably, or as required by National Electrical Code, the unit is intended to be installed within an electrical control enclosure. Operate where ambient temperatures do not exceed 140 °F (60 °C) or fall below 32 °F (0 °C) and relative humidity does not exceed 90%, non-condensing.

## FCC Compliance

This equipment has been tested and found to comply with the limits for a Class A digital device, pursuant to Part 15 of the FCC rules. These limits are designed to provide reasonable protection against harmful interference. This equipment can radiate radio frequency energy and, if not installed and used in accordance with the instructions, may cause harmful interference to radio communications. However, there is no guarantee that interference will not occur in a particular installation. If this equipment does cause harmful interference to radio or television reception, which can be determined by turning the equipment off and on, the user is encouraged to try to correct the interference by one or more of the following measures:

- Reorient or relocate the receiving antenna.
- Increase the separation between the equipment and the receiver.
- Connect the equipment to a power source different from that to which the receiver is connected.
- Consult the equipment supplier or an experienced radio/TV technician for help.

You are cautioned that any changes or modifications to this equipment not expressly approved in these instructions could void your authority to operate this equipment in the United States.

## Before Installing

### About this Document

The instructions in this document are for the ZXU1 controller which supports one mixing loop in a hydronic system.

### Inspecting the Equipment

Inspect the shipping carton for damage. If damaged, notify the carrier immediately. Inspect the equipment for damage. Return damaged equipment to the supplier.

### What is Not Included with this Equipment

- A power source for the equipment electronics and peripheral devices.
- Tools necessary to install, troubleshoot and service the equipment.
- The screws to mount the device.
- Peripheral devices, such as sensors, actuators, etc.
- Cabling, cabling raceway, and fittings necessary to connect this equipment to the power source, FTT-10A network and peripheral devices.

### Equipment Location



Abide by all warnings regarding equipment location provided earlier in this document.

Optimally, the equipment should be installed within a secure enclosure.

The equipment must be installed indoors unless contained within a protective enclosure. The enclosure must maintain internal temperature and humidity within the ranges specified for this equipment.

The equipment must be installed within 500 feet of all input peripherals (sensors, etc.) that will be connected to the equipment. It must be within 200 feet of any directly-connected thermostats.

## Selecting a Power Source

This equipment requires a UL recognized or CE marked (as appropriate) external power source (not supplied) to operate. The controller power input requires a voltage of 24 Volts AC.

To calculate power source current requirements, add the power consumption of all peripheral devices to that of the controller.

The controller and triac output loads can use the same power source. The loads must have EMF protection. This protection can be integral to the load, or installed across the load's coil.

To provide necessary RFI and transient protection, the controller's ground (GND) pin (T40) must be connected to earth ground. Failure to properly ground the controller may cause it to exceed FCC & CE limits. Excessive noise could also produce inaccurate sensor data. The power source must be capable of operating with the connection to ground described in "Wiring Information" on page 8.

## INSTALLATION



**Warning:** Electrical shock hazard. To prevent electrical shock or equipment damage, disconnect **ALL** power sources to controllers and loads before installing or servicing this equipment or modifying any wiring.

### Mounting the Device

1. Select a mounting location. Enclosure mounting is recommended.
2. Hold the controller on the panel you wish to mount it on. With a marker or pencil mark the mounting locations on the panel.
3. Using a small drill bit pre-drill the mounting holes.
4. Using two #6 pan head screws, mount the controller to the panel.
5. Wire the controller (See Routing Cabling to the Device).

Figure 1: Mounting Dimensions

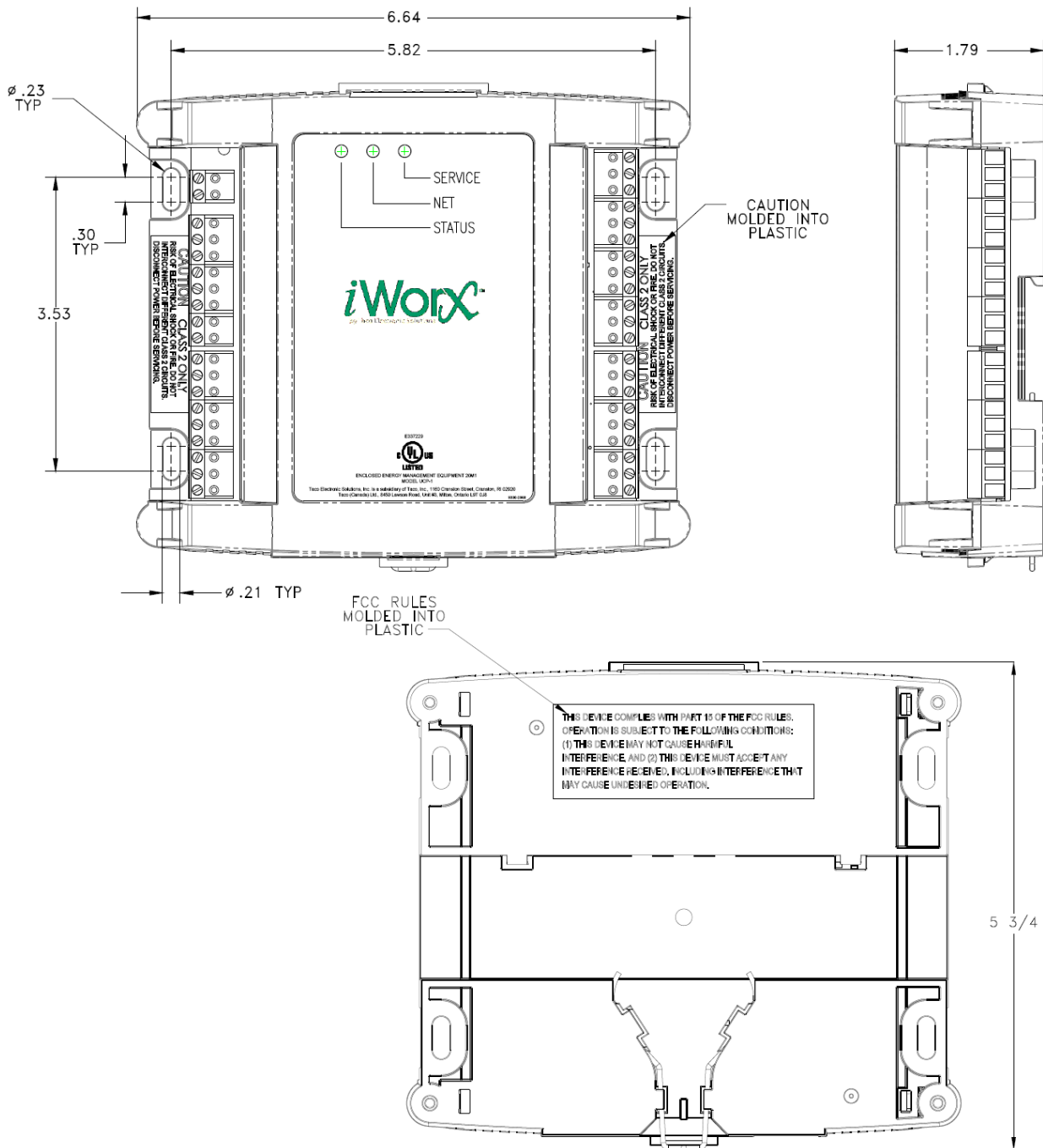

### Routing Cabling to the Device



Cabling used to connect the power source and cabling used to connect the FTT-10A network must remain separated within the control enclosure and wiring conduit.

## Grounding the Device



The ground terminal (T40) must be securely connected to earth ground. Failure to properly ground this equipment will result in improper operation. Improper grounding may also increase the risk of electrical shock and may increase the possibility of interference with radio/TV reception.



For best performance, connect the power supply common terminal (T38) to the same external point as the ground terminal (T40).

## WIRING INFORMATION

Figure 2: ZXU1 Power Sourcing

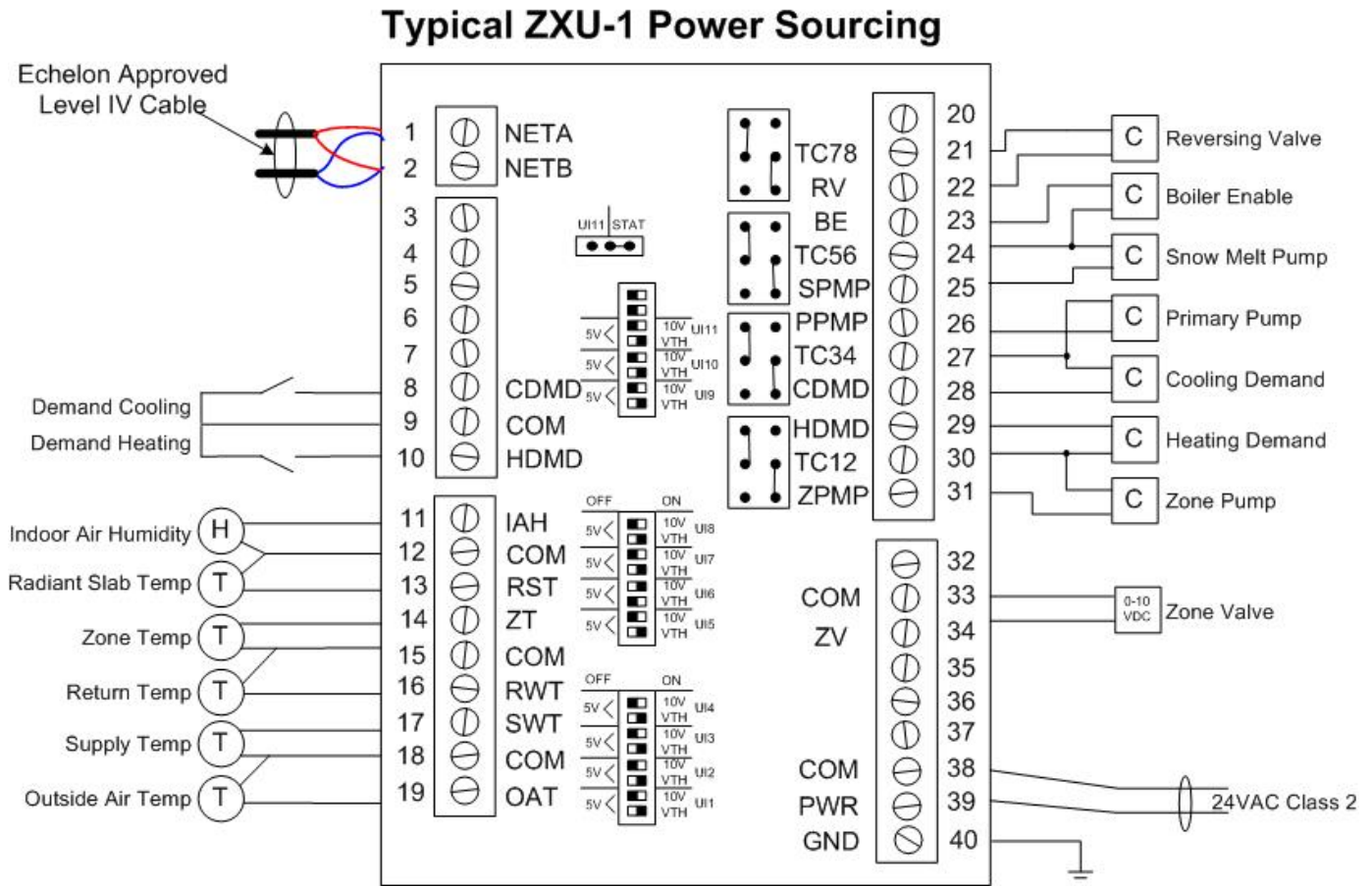

### Symbols

- 10 K ohm Precon Type III thermistor
- 24VAC pilot relay or contactor coil
- 0-10 VDC signal
- 0-10VDC Humidity Sensor

### Output Jumper Positions

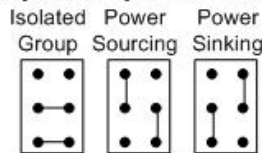

**Note:** Please be aware of the jumper positions. They must be set as shown in the drawing.



Figure 3: ZXU1 Power Sinking

### Typical ZXU-1 Power Sinking

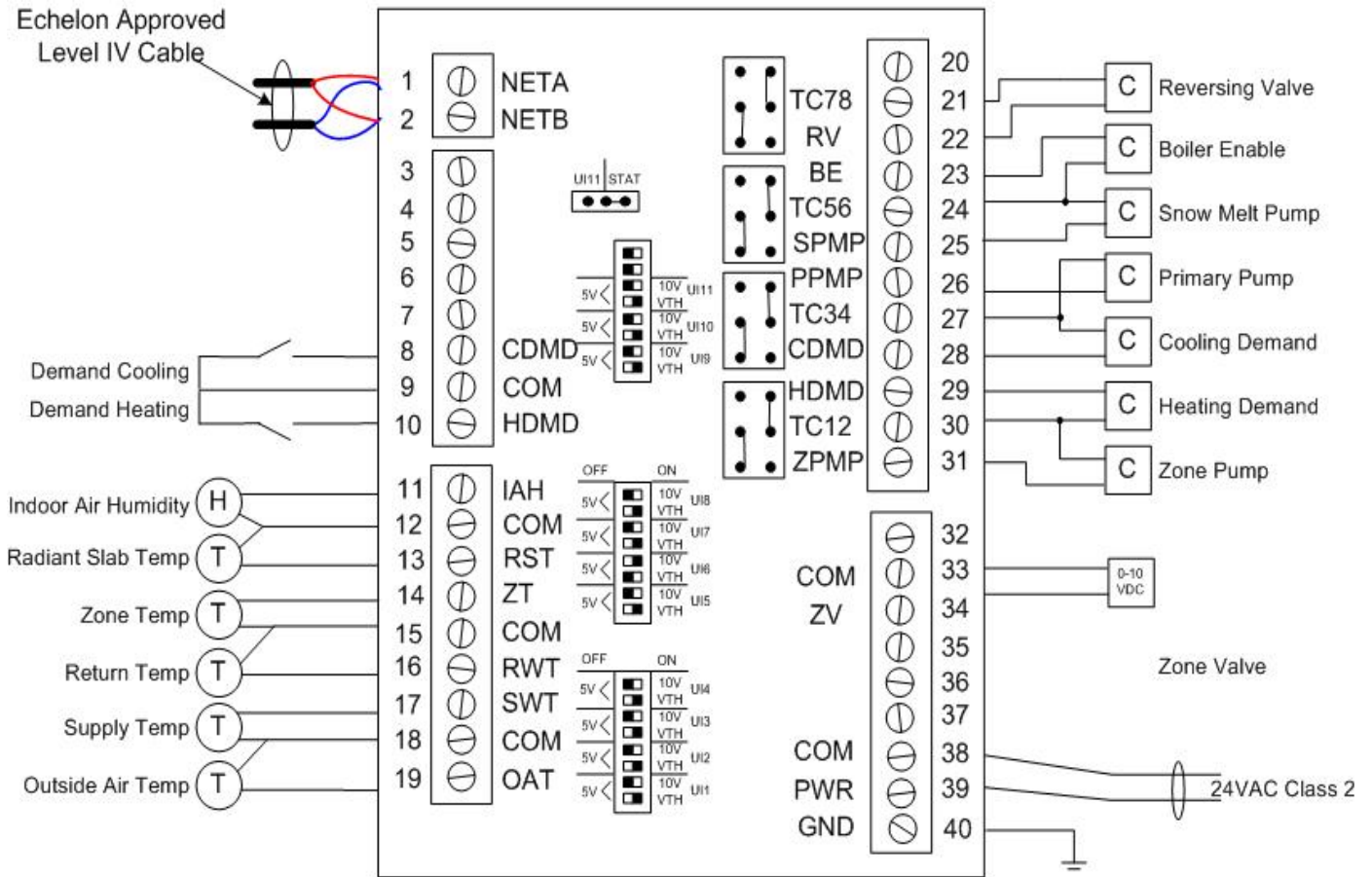

**Symbols**

- T 10 K ohm Precon Type III thermistor
- C 24VAC pilot relay or contactor coil
- 0-10 VDC 0-10 VDC signal
- H 0-10VDC Humidity Sensor

**Output Jumper Positions**

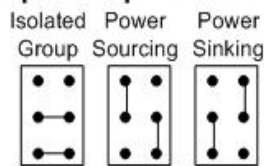
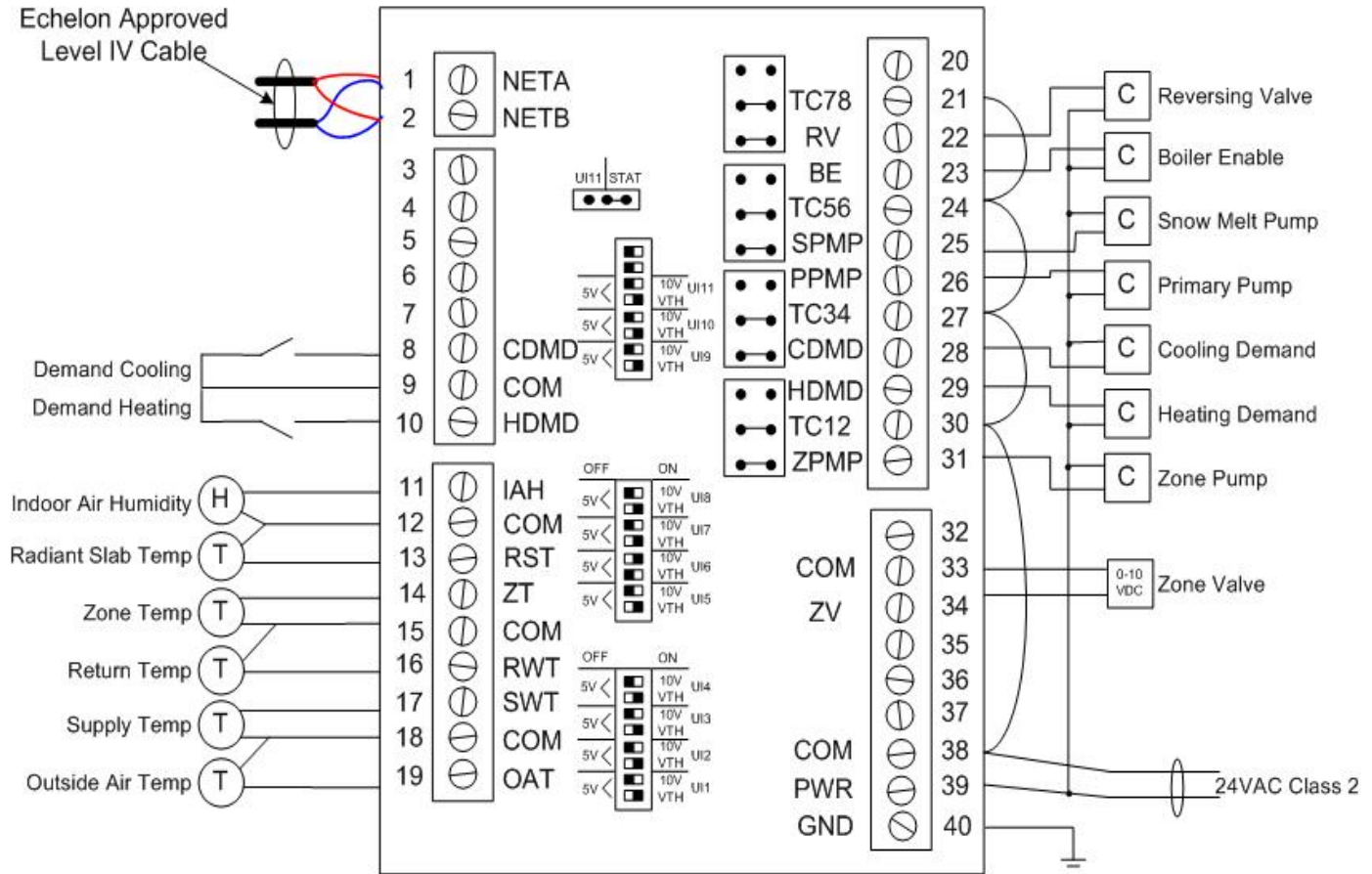

Figure 4: ZXU1 Power Isolated

### Typical ZXU-1 Power Isolated



**Symbols**

- 10 K ohm Precon Type III thermistor
- 24VAC pilot relay or contactor coil
- 0-10 VDC signal
- 0-10VDC Humidity Sensor

**Output Jumper Positions**

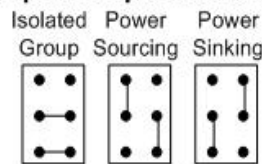

## Connecting Input Devices

### Outside Air Temperature (OAT) (Optional)

To connect the Outside Air thermistor to the unit, attach one wire from the thermistor to OAT (T19) and the other wire to the adjacent common (T18). The thermistor used must be 10K Precon Type III. This Thermistor is optional and the position can be left open in networked applications, when the Outside Air Temperature is communicated through an ASM-2.

### Supply Temperature (SWT)

To connect the Loop Supply Water thermistor to the unit, attach one wire from the thermistor to ST (T17) and the other wire to the adjacent common (T18). The thermistor used must be 10K Precon Type III.

### Return Temperature (RWT) (Optional)

To connect the Loop Return Water thermistor to the unit, attach one wire from the thermistor to RT (T16) and the other wire to the adjacent common (T15). The thermistor used must be 10K Precon Type III. This Thermistor must be populated when running differential snowmelt sequences.

### Zone Temperature (ZT) (Optional)

To connect the Zone Air thermistor to the unit, attach one wire from the thermistor to ZT (T14) and the other wire to the adjacent common (T15). The thermistor used must be 10K Precon Type III.

### Radiant Slab Temperature (RST) (Optional)

To connect the Radiant Slab thermistor to the unit, attach one wire from the thermistor to RST (T13) and the other wire to the adjacent common (T12). The thermistor used must be 10K Precon Type III. This Thermistor must be populated in Outdoor Reset Slab - Mode and whenever the slab temperature is critical.

### Indoor Air Humidity (IAH) (Optional)

To connect the Indoor Air Humidity sensor to the unit, connect the positive wire from the sensor to IAH (T11) and the other wire to the adjacent common (T12). The sensor must be of the 0-10 Volt type.

### Heat Demand (HDMD)

To connect the Heat Demand switch to the digital input, attach one wire of the contact to HDMD (T10) and the other wire to the adjacent common (T9). This must be a dry contact normally open switch.

### Cool Demand (CDMD)

To connect the Cool Demand switch to the digital input, attach one wire of the contact to CDMD (T8) and the other wire to the adjacent common (T9). This must be a dry contact normally open switch.

## Connecting Output Devices

The outputs for the zone valves or pumps must be connected to 24 VAC pilot relays. For a power isolated example please See "ZXU1 Power Isolated" on page 10.

**Note** that in the isolated group wiring, the 24VAC common is jumpered to the triac commons!

### Zone Pump Output (ZPMP)

The output for the Zone Pump Output must be connected to a 24 VAC pilot relay. Zone Pump Output [PWR] (T31, T39).

### Heat Demand Output (HDMD)

The heat demand output must be connected to a 24 VAC pilot relay. Connect the Heat Demand to [PWR] (T29, T39).

### Cool Demand Output (CDMD)

The cool demand output must be connected to a 24 VAC pilot relay. Connect the Cool Demand to [PWR] (T28, T39).

### Primary Pump Output (PPMP)

The outputs for the Primary Pump Output must be connected to a 24 VAC pilot relay. Primary Pump Output [PWR] (T26, T39)

### **Snow Melt Pump (SPMP)**

The output for the Snow Melt Pump must be connected to a 24 VAC pilot relay. Snow Melt Pump [PWR] (T25, T39)

### **Boiler Enable Output (BE)**

The output for the Boiler Enable must be connected to a 24 VAC pilot relay. Boiler Enable [PWR] (T23, T39)

### **Reversing Valve Output (RV)**

The reversing valve output must be connected to a 24 VAC pilot relay. Connect the Reversing Valve to [PWR] (T22, T39).

### **Modulating Output (ZV)**

The modulated output can be set to 0-10 V through the control logic. Connect the positive wire from the actuator to ZV (T34) and the other wire to COM (T33). See Wiring Details for further information.

Note: In this wiring example when T39 is referenced it is the same as indicating 24VAC!

## **Other Connections**

### **Network (LON)**

Network wiring must be twisted pair. One network wire must be connected to terminal NETA (T1) and the other network wire must be connected to terminal NETB (T2). Polarity is not an issue since an FTT-10A network is used for communications.

### **Power (PWR)**

Connect one output wire from a 24 VAC power supply to PWR (T39) and the other output wire from the power supply to the adjacent common terminal (T38).

### **Ground (GND)**



Terminal GND (T40) must be connected to earth ground. Failure to properly ground this equipment will result in improper operation. Improper grounding may also increase the risk of electrical shock, and may increase the possibility of interference with radio and TV reception.

# SPECIFICATIONS

## Electrical

### Inputs

- Cabling: twisted shielded pair, 18 AWG recommended 500 feet max. (152 meters)
- Resolution: 10 bit

### Indoor Air Humidity

- 0-10 Volt

### Outside Air Temperature, Supply Temperature, Return Temperature, Zone Temperature, Radiant Slab Temperature

- Precon Type III 10K thermistor

### Heat Demand, Cool Demand

- Dry Contact
- Normally Open

### Outputs

#### Zone Pump, Heat Demand, Cool Demand, Primary Pump, Snow Melt Pump, Boiler Enable, Reversing Valve

- 24 VAC
- 1A @ 50C, 0.5A @ 60C, limited by the Class 2 supply rating

### Modulating Output

- 0-10 Volt
- 2K Ohm minimum load
- 8 bit resolution

### Recommended Sensor Wire

Cable Type	Pairs	Details	Taco Catalog No.
18AWG	1	Stranded Twisted Shielded Pair, Plenum	WIR-018

### FTT-10A Network

- Speed: 78KBPS
- Cabling: Maximum node-to-node distance: 1312 feet (400 meters)
- Maximum total distance: 1640 feet (500 meters)

Cable Type	Pairs	Details	Taco Catalog No.
Level 4 22AWG (0.65mm)	1	Unshielded, Plenum, U.L. Type CMP	WIR-022

For detailed specifications, refer to the *FTT-10A Free-Topology Transceiver User's Guide* published by Echelon Corporation ([www.echelon.com/support/documentation/manuals/transceivers](http://www.echelon.com/support/documentation/manuals/transceivers)).

## Power

### Power Requirements

- 24VAC (20VAC to 28VAC), requires an external Class 2 supply

### Power Consumption

- 7.2W with no external loads, maximum limited by the Class 2 supply rating

## Mechanical

### Housing

- Dimensions: 5.55" (141mm) high, 6.54" (166 mm) wide, 1.75" deep (44 mm)
- ABS

### **Weight**

- Controller Weight: 0.70 pounds (0.32 kilograms)
- Shipping Weight: 1.0 pounds (0.46 kilograms)

### **Electronics**

- Processor: 3150 Neuron 10 MHz
- Flash: 48 Kilobytes
- SRAM: 8 Kilobytes
- Termination: 0.197" (5.0 mm) Pluggable Terminal Blocks, 14-22 AWG

### **Environmental**

- Temperature: 32 °F to 140 °F (0 °C to 60 °C)
- Humidity: 0 to 90%, non-condensing

### **Agency Listings**

- UL Listed for US and Canada, Energy Management Equipment PAZX and PAZX7.

### **Agency Compliances**

- FCC Part 15 Class A

## APPLICATION DESCRIPTION

The ZXU1 controller provides control for a modulating 0-10V output used for injection or mixing valves in radiant systems. The modulating output is controlled according to the Setpoint Mode by a variety of temperature inputs and/or a demand input (xDMD). The demand can be for heating or cooling and will be controlled accordingly.

The outside air temperature (OAT) is communicated across the network or can be obtained from a sensor input in the standalone mode. The outside air temperature is used to calculate the reset temperature for the loop. The outdoor air temperature can be averaged over a period of *OATSamples* numbers of days, where *OATSamples* can be configured for up to 5 days, if set to zero, the current OAT is taken.

The controller controls the modulating output according to the control algorithm and also provides contact closures for the triac outputs.

# Application Examples

Figure 5: Three loops with mixing valves.

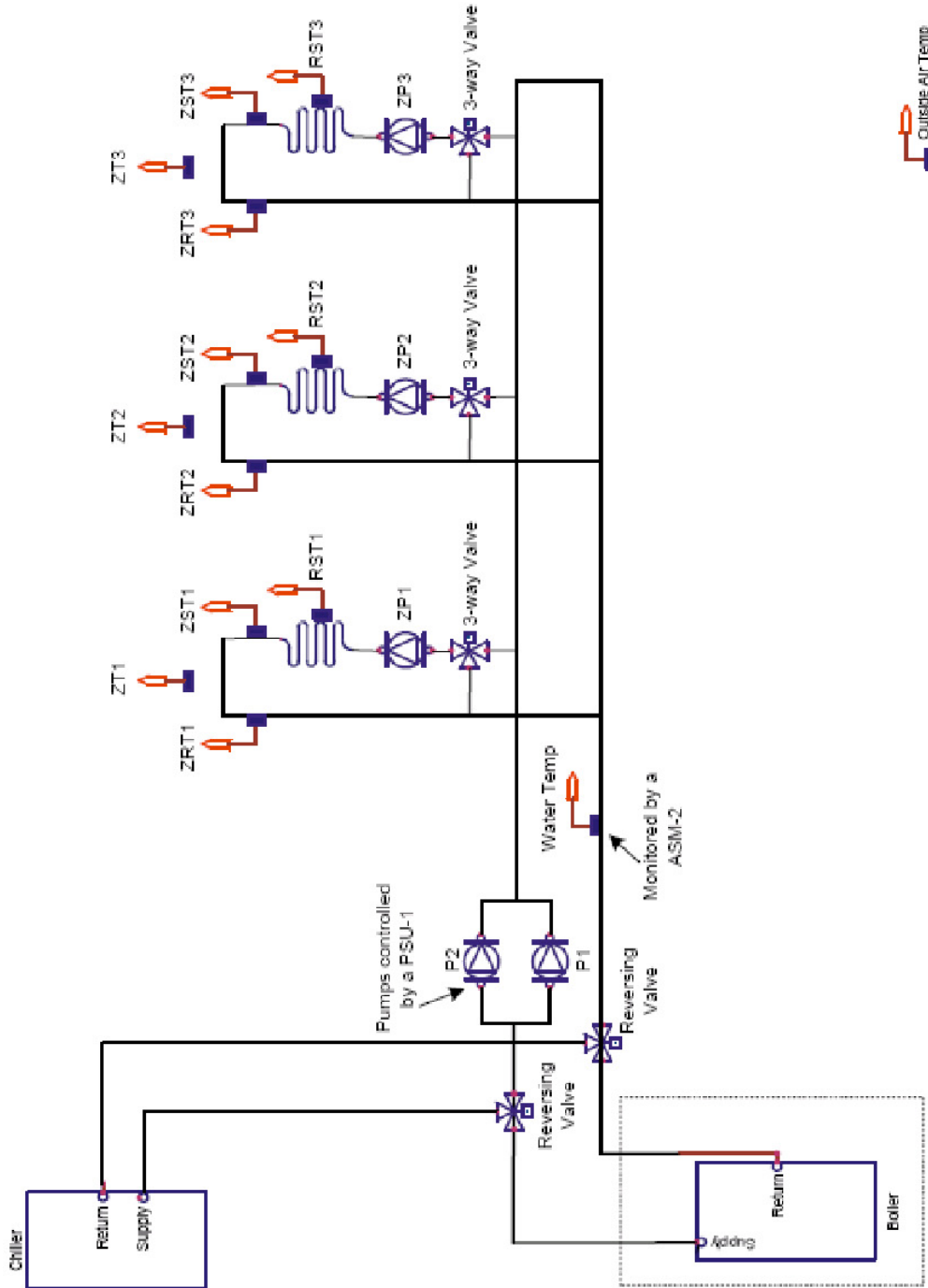



**Figure 6: Loop in Snow Melt Mode**

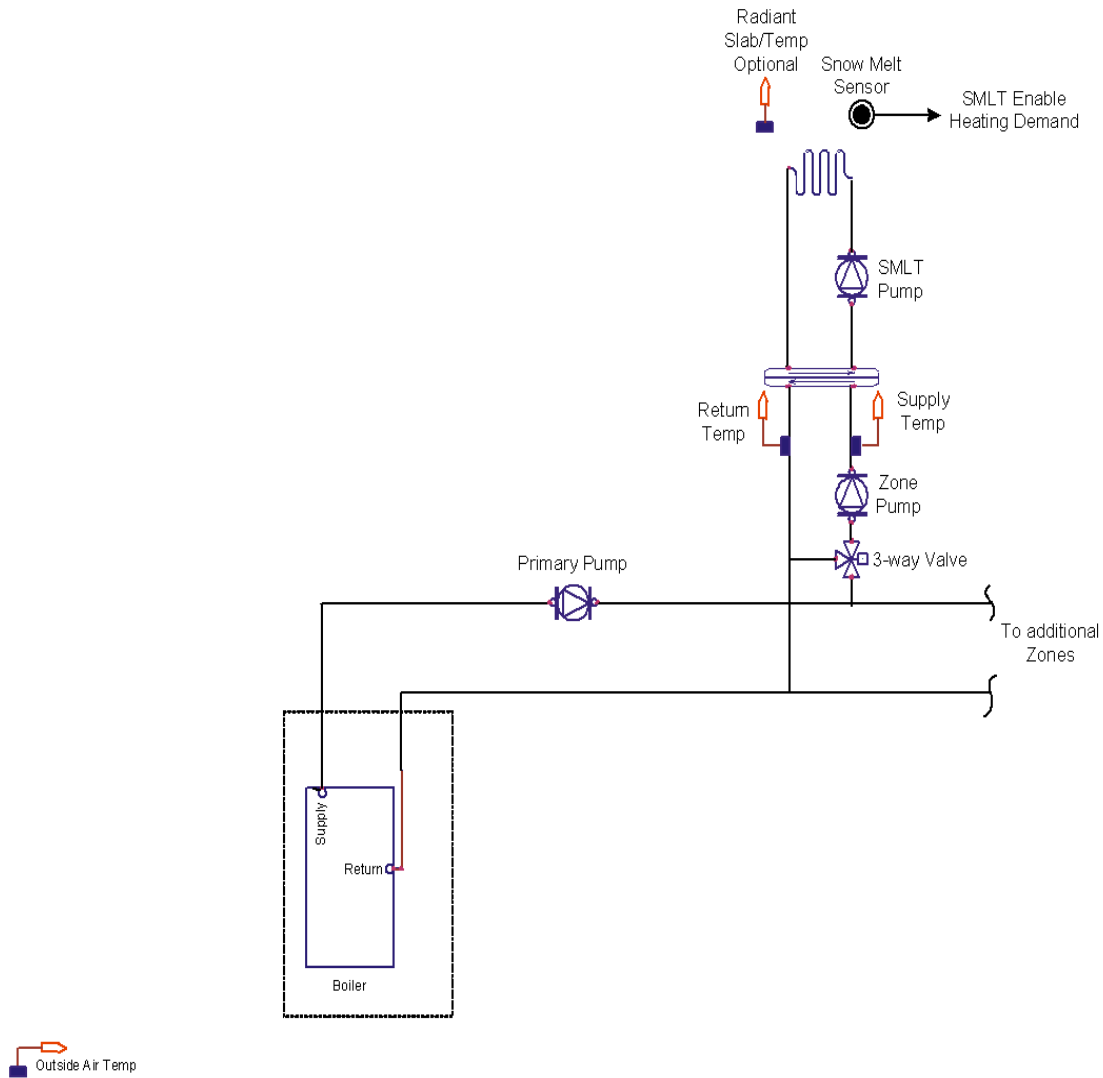

## SEQUENCE OF OPERATION

### Outdoor Temperature Influence

The Outdoor Air Temperature can be averaged over a configurable number of days as configured in *OATSamples*. If this variable is set to 0, only the current Outside Air Temperature will be used for the Outdoor Reset Setpoint calculation.

### Setpoint Calculation

The Setpoint for the PI Loop can be one of five different choices, Outdoor Reset, Outdoor Reset Slab, Zone Setpoint, SMLT Differential and Snowmelt. While in Outdoor Reset Setpoint, Snowmelt and Snowmelt Differential an additional Demand (Heat or Cool) is needed to enable the control, Outdoor Reset Slab and Zone Setpoint operate completely by comparing the calculated Setpoint to the appropriate control temperature, which is the slab temperature in Outdoor Reset Slab mode and the Room or Zone Temperature in Zone Setpoint Mode.

Both Snowmelt Setpoint calculations are only effective, when in Winter (Boiler) Mode. In Summer (Chiller) Mode they will be set to simple Reset Setpoint.

### Outdoor Compensated Loop Supply Setpoint

#### Heating or Winter Mode

When the *Setpoint Mode* is set to “Outdoor Reset” the loop control setpoint is determined by the loop reset curve, which compensates for changes in the heating load caused by varying outdoor air temperature (OAT). An example is shown in Figure 7. As Outside Air Temperature decreases, the loop supply setpoint is increased to compensate for the greater heating load. The slope of the loop reset curve is determined by the High and Low points of the reset curve for heating found in *ResSetHeat*. *OAT Reset Low* is the outdoor design heating temperature at which the boiler setpoint is *Reset High*, the highest temperature required in the loop for space heating. The lower end of the reset curve is defined by the *Reset Low* setpoint and *OAT ChangeOver*. The *OAT Heating Cutoff* is the temperature above which space heating demands are disabled (sometimes referred to as “Warm Weather Shutdown”). It may be higher or lower than *OAT ChangeOver* as determined by the application requirements. 65 °F (18 °C) may be a suitable cutoff for a building with good heat retention or other heat gains, while 75 °F (24 °C) may be more appropriate for a building with high heat loss and extra heating requirements. The *OAT Heating Cutoff* is subject to a 1 °F (0.55 °C) hysteresis.

If the slab sensor is installed and the *Setpoint Mode* is set to “Outdoor Reset”, the slab temperature will also be checked. If the slab temperature is above the supply temperature + *Alarm Temp offset*, the demand will be ramped down to 0% to protect the floors.

#### Cooling or Summer Mode

When the *Setpoint Mode* is set to “Outdoor Reset” the loop control setpoint is calculated in the same manner described for Heating or Winter Mode, except the Reset Curve for Cooling can have a different slope to accommodate the Humidity within the cooled environment (as shown in Fig. 3). The Reset curve can be defined in *ResSetCool*. The slope of the loop reset curve is determined by the High and Low points of the reset curve for cooling found in *ResSetCool*. *OAT ChangeOver* is the outdoor design cooling temperature at which the cold water setpoint is *Reset High*, the appropriate temperature required in the loop for space cooling. The lower end of the reset curve is defined by the *Reset Low* setpoint and *OAT Reset High* point. The *OAT Heating CutoffLo* is the temperature below which space cooling demands are disabled.

If *DewPoint Enabled* is set to yes the Dew Point Temperature is calculated and compared to the Radiant Slab Temperature. If the DewPoint Temperature is lower than the Radiant Slab Temperature, the Effective Setpoints gets adjusted to avoid dewpoint conditions.

Note: In order to activate the dewpoint check, the Radiant Slab Temperature Sensor and the Indoor Air Humidity Sensor must be populated, and the *Dewpoint Enabled* must be set to Yes.

## Outdoor Compensated Loop Supply Setpoint with Slab Temperature influence

When the *Setpoint Mode* is set to “Outdoor Reset Slab” the loop demand is calculated the same way as the above setpoint with the difference, that no demand is necessary to start the control. The slab temperature is compared to the calculated reset temperature. In order to achieve the temperatures in the slab, the actual supply temperature is calculated with an offset. Depending on the Operating Mode (Summer/Winter Operation) the *HeatOffset* is added to the Reset Setpoint in winter operating mode and the *CoolOffset* is subtracted from the Reset Setpoint in summer operating mode. This allows for fine tuning the loop.

**Figure 7: The Loop Reset Curve in Winter Mode (Heating)**

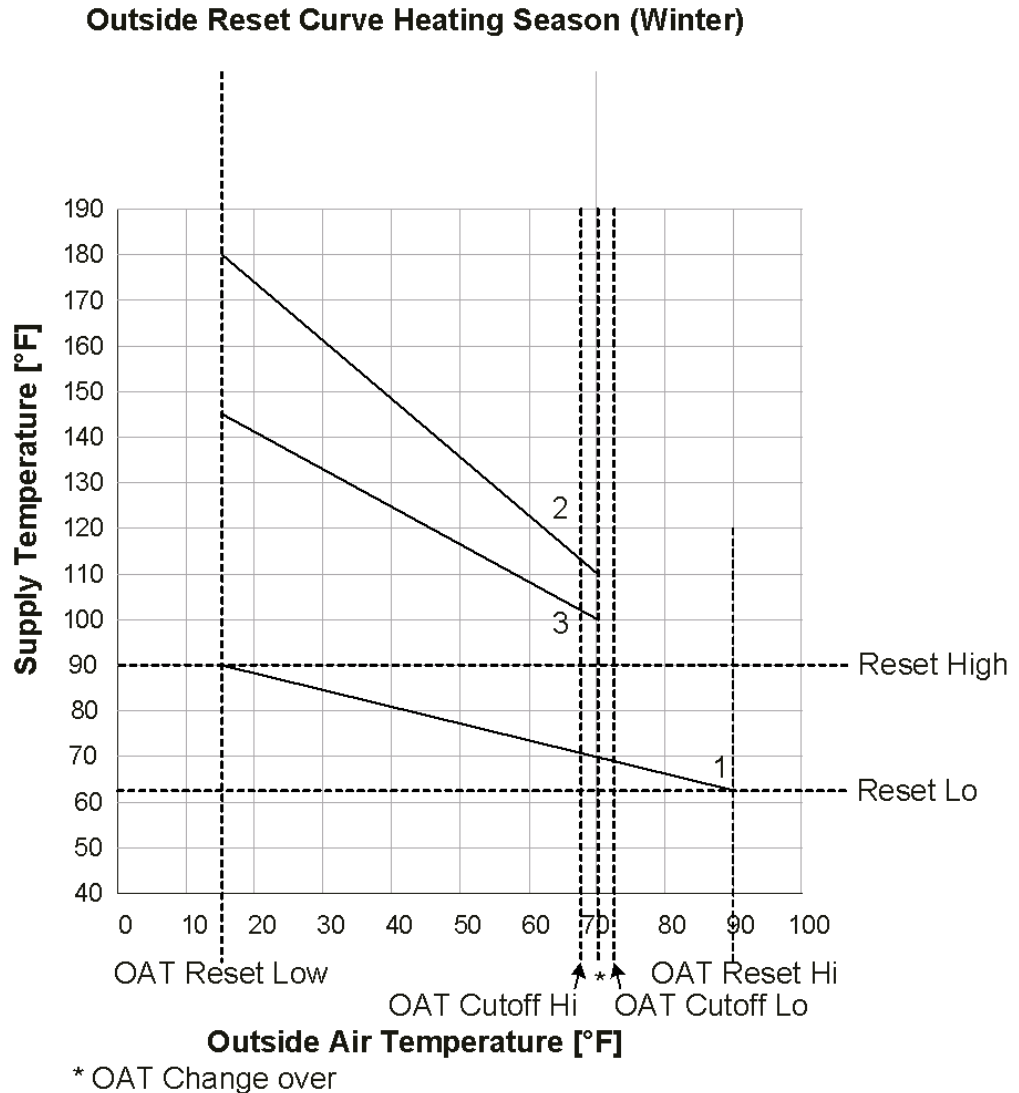

Curve 1 shows a combined heating/cooling reset curve in a low temperature range. The controlled Temperature is the Radiant Slab Temperature. Humidity control is addressed by another control system (such as the DXU-4) and held constant at 40%.

Curve 2 depicts a high temperature reset curve.

Curve 3 depicts a lower temperature reset curve.

Note: Since every installation is different, the above values are typical values and have to be adjusted for each application.

## Room Temperature Setpoint

When the *Setpoint Mode* is set to “Zone Setpoint” the loop is controlled towards a Zone Temperature Setpoint. In order to compensate long lasting thermal processes, a maximum increase per time segment can be configured (*SoftStartRate*) after which the *Effective Setpoint* gets increased by 0.5F. The Zone Temperature control is subject to occupied/unoccupied as well as heating/ cooling setpoints. All necessary temperature setpoints and settings can be entered into the *Zone Setpoints* structure.

## Snowmelt Setpoint

When the *Setpoint Mode* is set to “Snowmelt” the Snowmelt Setpoint is calculated exactly like the Reset Setpoint with the difference that the Reset Hi and Reset Lo Temperatures must be set to Low Temperatures to accommodate the slab and the demand is generated by a Snow Melt Sensor wired into the Heat Demand Input.

## Snowmelt Setpoint with Differential

When the *Setpoint Mode* is set to “SMLT Differential” the Snowmelt Setpoint with differential is based on the difference between Supply Temperature and Return Temperature. If the difference between Supply and Return Temperature is greater than the *Max Differential* in the *Snowmelt Settings*, the *Effective Setpoint* gets clamped to the Supply Temperature. After the *Max Differential* has decreased and gone back within the limit, the setpoint gets increased in discrete steps and configurable time segments, *SoftStartRate*, towards the calculated Reset Setpoint.

Figure 8: The Reset Curve in Summer Mode

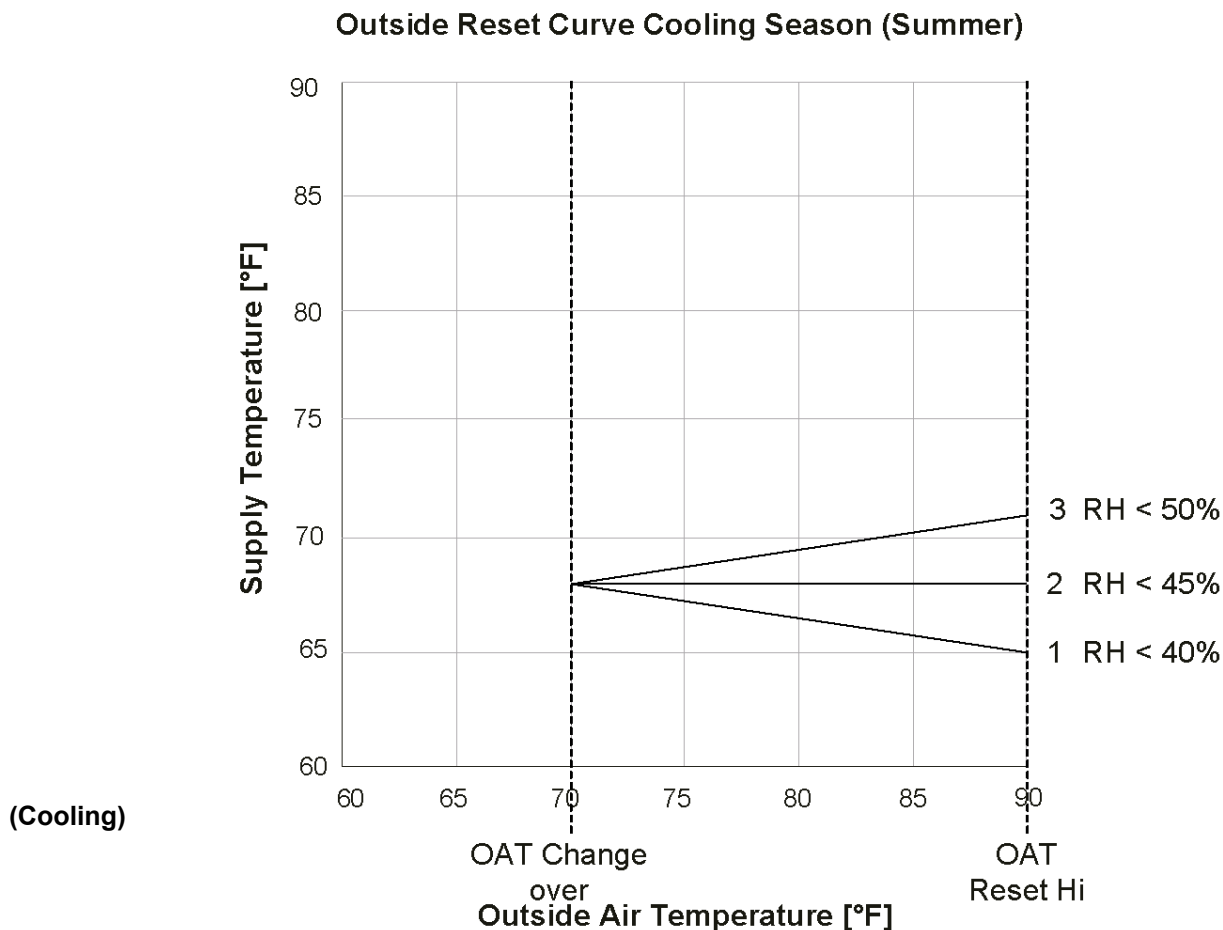

## Boiler Protection

To ensure that the temperature of the boiler loop return does not drop below the manufacturer's recommendations, the ZXU controller maintains the *Boiler Pro* temperature while there is a demand. Loads are held off or reduced until the temperature is high enough or until 30 minutes have lapsed. Until the Boiler Return temperature has recovered completely, the ZXU will keep switching to a hold off Scenario in a 30 minute interval. Boiler Protection works only under the following circumstances:

- The ZXU is connected and associated to a BLM-type controller and the BLM Return Temperature Sensor is populated.
- If no BLM is connected then the Return Temperature sensor on the ZXU must be populated.
- the *Boiler Pro* is set in the Reset Settings structure to a value > 42 DegF

The ZXU1 will resume normal operation, when:

- the Boiler Return Temperature has recovered to *Boiler Pro* + 15DegF
- Loads have been off for 30 minutes.

## Demand

The demand depends on the *Operating Mode* and the *Setpoint Mode* that the controller is set to. It can be in Summer/cooling or Winter/heating mode set by the *OPMode* variable or through the LCI2 in a networked Environment. The *SPMode* defaults to Reset Setpoint and can also be configured to Reset Setpoint Slab, Setpoint, Snowmelt and Snowmelt with Differential as described in Setpoint Calculation.

### Reset Setpoint, Snowmelt and Snowmelt Differential

Heating and Cooling Demands are detected by the HDMD or CDMD Inputs. The demands are created using a Thermostat or a SnowMelt Sensor. The valve starts modulating, whenever the Supply Temperature is below (Winter) or above (Summer) the *Effective Setpoint*.

If the Radiant Slab Sensor is populated, the Radiant Slab Temperature gets compared to the *Effective Setpoint* plus the *Alarm Temp Offset* and the demand is turned off if this value is exceeded.

### Reset Setpoint Slab, Setpoint

The appropriate Temperature is compared to a setpoint, Reset Setpoint minus heating or cooling offset or Room Temperature Setpoint. If it is below this Effective Setpoint a demand is assumed and the modulating output is enabled.

### Zone Setpoint

The Effective Setpoint follows initially the Outdoor Reset Setpoint. Whenever the Zone Temperature can not be achieved, a discrete temperature offset is added to the Effective setpoint in *SoftStartRate* time intervals.

## Valve Output

To maintain the proper supply temperature for the radiant zone, the modulating output of the ZXU-1 controls a mixing valve or injection pump. The output may be configured for a minimum and a maximum anywhere between 0-10 V, which is suitable for many mixing valves and some injection pumps. Common line voltage circulators require a signal converter for proper pump speed control. Use only devices approved by the pump manufacturer.

### Modulated Valve Operation

The mixing device is controlled using a proportional and integral feedback loop. When the demand is satisfied (<1%), the output is disabled. Parameters for the valve can be set in *Valve Settings*.

## Digital Outputs

### Zone Pump Output

The Secondary Pump (also referred to as Zone Pump) is turned on whenever there is a heat or cool demand and the Modulated Valve is enabled and off when it drops below 1%. It may be set for Continuous Pump Circulation subject to the OA heating cutoff in the Winter Mode or *Heating and Cooling Cutoff* in Summer Mode.

### Heating Demand

The Heat Demand output is turned on, whenever a valid heat demand is detected. For detailed information see Demand Topic.

### Cooling Demand

The Cool Demand output is turned on, whenever a valid cool demand is detected. For detailed information see Demand Topic.

### Primary Pump Output

Whenever there is a demand for heating and the Zone Pump comes on, the Primary Pump comes on as well.

### Snow Melt Pump Output

The Snow Melt pump and Zone Pump are both enabled, when there is a call to melt snow and the controller is in one of the two snow melt modes.

## **Boiler Enable**

When there is a demand for heating and the Modulated valve output is above the “On” setting, the Boiler Enable is turned on.

## **Reversing Valve**

The reversing valve switches the supply water from boiler supply in Winter mode to chiller supply in Summer mode. The operating mode can be configured to match the required default state.

## **Standalone Operation**

The ZXU-1 Controller can be used in standalone operation, but it must be configured using an LCI2. The Outside Air Temperature Sensor needs to be populated in order to correctly calculate the Outdoor Reset Setpoint.

## **Networking**

The Controller can be used in conjunction with a BLM-series controller. The Network needs to be configured to associate the appropriate Boiler and Mixing Units. This is accomplished by selecting the Boiler controller and enabling the ZXUs found under the “Members” button.

## CONTROLLER IDENTIFICATION

The controller must be configured by the LCI2 in order to set the controller's schedules, change its setpoints, etc. To allow the LCI to identify the ZXU1, the controller's service pin must be pressed after the controller is installed and the LCI is active on the network. The controller's status light flashes green until it is configured, and will be solid green after it is configured.

## Inputs

The Input Screen lists the major inputs of the ZXU1, and shows their current values. None of these values can be changed from this screen.

Name	Range	Description
Outside Temp	-29 to 230°F (-33 to 110°C)	Outside Temp from a networked ASM-2.
OAT	-29 to 230°F (-33 to 110°C)	Outdoor temperature from the ZXU when run in stand-alone mode or as reported by the BLM series Controllers associated to this ZXU1.
Supply Temp	-29 to 230°F (-33 to 110°C)	Supply water temperature in the loop.
Return Temp	-29 to 230°F (-33 to 110°C)	Return water temperature in the loop or Boiler Return Temperature
Zone Temp	-29 to 230°F (-33 to 110°C)	Zone Temperature.
Radiant Slab Temp	-29 to 230°F (-33 to 110°C)	Radiant Slab Temperature
Heat Demand	Off, On	Status of the Heat Demand input
Cool Demand	Off, On	Status of the Cool Demand input
WWSD	Off, On	Status of the Outside Air Cutoff Temperature (also referred to as Warm Weather Shutdown)
SMLT Cutoff	Off, On	Status of the Snowmelt Cutoff (Temperature below which Snowmelt is disabled)
Req Shutdown	Off, On	Status of the Shutdown process
Temp Low Alarm	Off, On	Status of the Alarm
Setp Demand	Off, On	Status of the Setpoint Demand
Reset Demand	Off, On	Status of the Reset Demand
Indoor Air Humidity	0.00 to 100.00%	Humidity reported by the IAH sensor.
Occupancy Mode	Occ, Unocc	Current Occupancy Mode of the ZXU-1



## Outputs

The Outputs Screen lists the outputs of the ZXU1, and shows their current values. None of these values can be changed from this screen

Name	Range	Description
Unit Status	Structure	
Application Mode	Cool, Heat	Mode in which the ZXU operates. cool mode will activate a cooling sequence, heat mode will activate the heating sequences
Heat Demand	Off, On	Status of Heat Demand
Cool Demand	Off, On	Status of Cool Demand
Mixing Output	0.00% to 100.0%	Status of the output to the injection pump or mixing valve.
Zone Pump	Off, On	Status of the zone pump
Primary Pump	Off, On	Status of the primary pump
SMLT Pump	Off, On	status of the snowmelt pump
Boiler Enable	Off, On	Enable signal for a boiler
Rev Valve Pos	Open, Closed	Position for the reversing valve to accommodate summer or winter operation
Effective Setpt	-29 to 230°F (-33 to 110°C)	Calculated Setpoint that the injection/mixing control operates
Day Of Week	Not Set, Monday, Tuesday, Wednesday, Thursday, Friday, Saturday, Sunday	Day Of the Week currently set in the RTC

The table above list all possible readings on the ZXU1. Some of the output readings are structures themselves and will be described in the tables below.

### Unit Status

Setting	Range	Description
Mode	Heat, Cool, Off, Shut down	Current Operating mode of the ZXU1.
Heat Output	0.00% to 100.00%	Current status of the heating output.
Cool Output	0.00% to 100.00%	Current status of the cooling output.
Zone Pump Output	0.00% or 100.00%	Current status of the zone pump output.
In Alarm?	Yes, No	Alarm indication

## Configuration

### All Settings

The All Settings screen lists all of the variables and structures used to configure the ZXU1.

Name	Range	Default Value	Description
OAT Settings	Structure		Reset and cutoff setpoints for the controller
Reset Settings Heat	Structure		Reset Curve Settings for Heating
Reset Settings Cool	Structure		Reset Curve Settings fore Cooling
Zone Setpoints	Structure		Zone Setpoint Settings
SMLT Settings	Structure		Snowmelt settings

Name	Range	Default Value	Description
Valve Settings	Structure		Settings for the modulation output of this Injection Mixing controller
Rev Vlv Action	Energize on Heat, Energize on Cool	Energize on Heat	Settings for the reversing valve
Soft Start Rate	0-100 Min	0 Min	Time span in which the calculated setpoint is raised (only in SMLT Differential and Setpoint Mode)
Offset Heat	+/-10°F (+/-5.56°C)	0°F	Offset to calculated Reset Temperature when in Slab Mode
Offset Cool	+/-10°F (+/-5.56°C)	0°F	Offset to calculated Reset Temperature when in Slab Mode
Const Pump Circ	Auto, On	Auto	When set to Auto, zone pump comes on with demand, when set to on pump is always on regardless of demand
Pump Exercise	Off, On	Off	When set to On, pump will exercise for 15 sec, when the maximum idle time has lapsed
Setpoint Mode	Outdoor Reset, Outdoor Reset Slab, Zone Setpoint, SMLT Differential, Snowmelt	Outdoor Reset	Determines, what setpoint calculation is being used. Outdoor reset, advanced outdoor reset calculation, or zone setpoint calculation
Operating Mode	Summer, Winter, Auto	Winter	Controller operating mode for Summer and Winter operation. Has influence on Reversing valve position as well as valve modulating sequences
OAT Samples	0-4	0	number of days OAT samples get taken
Alarm Temp offset	0-10°F (0-5.56°C)	5°F (2.66°C)	Offset to the appropriate Temperature before an alarm gets sent to the LCI
Alarm Enabled	Yes, No	No	If set to yes, the Temperatures get checked according to the Alarm Temp Offset
Dew Point Enabled	Yes, No	No	If set to yes, the calculated loop control setpoint is compared to the dew point temperature and adjusted if necessary.
Day Of Week	Not set, Monday, Tuesday, Wednesday, Thursday, Friday, Saturday, Sunday	Not set	Current Day of the Week
WDay Occ. Time	Structure		Time to begin occupied period for the local backup schedule on weekdays.
WDay Unocc. Time	Structure		Time to begin unoccupied period for the local backup schedule on weekdays.
WEnd Occ. Time	Structure		Time to begin occupied period for the local backup schedule on weekends.
WEnd Unocc. Time	Structure		Time to begin unoccupied period for the local backup schedule on weekends.

The table above lists all possible settings on the ZXU1. Some of the settings are structures themselves and will be described in the tables below.

## OAT Settings

Displays all of the OAT settings and provides access to edit these parameters from a single screen.

Name	Range	Value	Description
Reset Low	-29 to 50°F (-34 to 10°C)	15°F (-20°C)	Outside air temperature at which the water temperature is at its highest.
Reset High	41 to 122°F (5 to 50°C)	90°F (20°C)	Outside air temperature at which the water temperature is at its lowest.
Cutoff Temp Heat	41 to 122°F (5 to 50°C)	64°F (20°C)	Outside air temperature above which the heating reset demand is disabled.
Cutoff Temp Cool	41 to 122°F (5 to 50°C)	66°F (20°C)	Outside air temperature below which cooling is disabled when in summer mode
Change Over	41 to 122°F (5 to 50°C)	65°F (20°C)	Temperature at which the controller switches between summer and winter modes of operation
Offset	-180 to 100°F (-100 to 55.56°C)	0°F	Offset for Outdoor Temperature Sensor

## Reset Settings Heat

Displays all of the Reset Settings Heat settings and provides access to edit these parameters from a single screen.

Name	Range	Default Value	Description
Reset Low	41 to 185°F (5 to 85°C)	69°F (20°C)	Lowest supply temperature desired when warm outside.
Reset High	41 to 230°F (5 to 110°C)	79°F (26°C)	Highest supply temperature desired when cold outside.
Boiler Pro	41 to 185°F (5 to 85°C)	42°F (5°C)	Boiler Protection Temperature, Lowest Return Water Temperature to return to the Boiler

## Reset Settings Cool

Displays all of the Reset Settings Cool settings and provides access to edit these parameters from a single screen.

Name	Range	Default Value	Description
Reset Low	41 to 185°F (5 to 85°C)	65°F (20°C)	Lowest supply temperature desired when warm outside.
Reset High	41 to 230°F (5 to 110°C)	69°F (18°C)	Highest supply temperature desired when cold outside.

## Zone Setpoints

Displays all of the Zone Setpoint settings and provides access to edit these parameters from a single screen.

Settings	Range	Default	Description
Setpoint	40 to 95 °F (4.45 to 35 °C)	71.0°F (21 °C)	Setpoint for occupied time periods. The Setpoint can be set as low as 40°F in order to accommodate Snow melt Settings.
Cooling Offset	0 - 10.0 °F (0 to 5.56 °C)	1 °F (0.55 °C)	This value is used to calculate the cooling SP by adding to the SP
Heating Offset	0 - 10.0 °F (0 to 5.56 °C)	1 °F (0.55 °C)	This value is used to calculate the heating SP by subtracting from the SP
Unocc Cooling	50 to 95 °F (10 to 35 °C)	82.0°F (27.7 °C)	Cooling setpoint for unoccupied time periods.
Unocc Heating	50 to 95 °F (10 to 35 °C)	60.0°F (15.5 °C)	Heating setpoint for unoccupied time periods

## SMLT Settings

Displays all of the Snowmelt settings and provides access to edit these parameters from a single screen

Settings	Range	Default	Description
Override	Off, On	Off	Status of the Override.
Cutoff Temp	-29 to 41 °F (-34 to 5 °C)	-4 °F (-10 °C)	Outside temperature below which snow melt is disabled.
Max Differential	0 to 40°F (0 to 22.2°C)	20°F (11°C)	Max Temperature Difference between Boiler Supply and Boiler Return Temperature.

## Modulating Valve Settings

Displays all of the Modulating Valve settings and provides access to edit these parameters from a single screen.

Name	Range	Default	Description
Kp	0-20%	1%	Proportional Constant for the PI loop
Ki	0-20%	0.05%(compares to 10min)	Integral Constant for the PI loop
On	0-100%	30%	Demand at which Boiler gets Enabled
Ramp Up	0-20%	1%	If set to other than 0, Gain for Setpoint demand Ramp up
Ramp Down	0-20%	0.5%	If set to other than 0, Gain for Ramp down request
Out Min	0-10V	0.5V	Voltage, at which the modulated output is at 0%
Out Max	0-10V	10V	Voltage, at which the modulated output is at 100%

## Backup Schedules- WDay and WEnd Occupied and Unoccupied Time

Displays all of the Backup Schedules settings and provides access to edit these parameters from a single screen.

Setting	Range	Default	Description
Hours	0-23	0	Military time for the hour of the day when the occupied or unoccupied state starts
Minutes	0-59	0	Minute, when occupied or unoccupied state starts

## Alarms

Temperatures are monitored only if the Setting for *Alarms Enabled* is set to "On". Temperatures for alarms depend on the *Setpoint Mode* and are calculated as described in the table below.

An alarm is communicated to the LCI when the Temperature is outside the target range described in the section "Sequence of Operation."

## Alarm conditions

Alarm	Range	Alarm Trigger	Alarm Reset
Supply Temperature High	Normal, Alarm	Current Supply Setpoint + Alarm Temp Offs	Current Supply Temperature is below the Setpoint + Alarm Temp Offs
Supply Temperature Low	Normal, Alarm	Current Supply Setpoint -Alarm Temp Offs	Current Supply Temperature is above the Setpoint - Alarm Temp Offs
Return Temperature High	Normal, Alarm	Current Return Setpoint + Alarm Temp Offs	Current Return Temperature is below the Setpoint + Alarm Temp Offs
Return Temperature Low	Normal, Alarm	Current Return Setpoint -Alarm Temp Offs	Current Return Temperature is above the Setpoint - Alarm Temp Offs
Zone Temperature High	Normal, Alarm	Occupied/Unoccupied Setpoint + Alarm Temp Offs	Current Zone Temperature is below Occupied/Unoccupied Setpoint + Alarm Temp Offs
Zone Temperature Low	Normal, Alarm	Occupied/Unoccupied Setpoint - Alarm Temp Offs	Current Zone Temperature is above Occupied/Unoccupied Setpoint - Alarm Temp Offs
Radiant Slab Temperature High	Normal, Alarm	Radiant Slab Temperature + Alarm Temp Offs	Current Radiant SlabTemperature is below Setpoint - Alarm Temp Offs
Radiant Slab Temperature Low	Normal, Alarm	Radiant Slab Temperature - Alarm Temp Offs	Current Radiant Slab Temperature is above Setpoint - Alarm Temp Offs

# TROUBLESHOOTING

## Diagnostic LEDs

The controller has 3 LED indicators. These indicators can aid in troubleshooting equipment operation problems. The following table lists the functions of the controller's LEDs in the order they appear from left to right on the unit.

LED	Indication
Status	<ul style="list-style-type: none"> <li>- Solid green when running and configured by an LCI (networking)</li> <li>- Flashing green when running and NOT configured by an LCI (stand-alone)</li> <li>- Solid red when a fault condition exists (control shut down)</li> <li>- Blinking Red - the controller has a device failure</li> <li>- Solid Amber - The controller has not received a LCI ping message in over 10 minutes and is part of a network.</li> </ul>
Network	<ul style="list-style-type: none"> <li>- Yellow while the controller is transmitting data onto the FTT-10A network</li> <li>- Green when there is network activity</li> <li>- Off when there is no network activity</li> </ul>
Service	<ul style="list-style-type: none"> <li>- Illuminated when the service pin is depressed or when a controller gets configured by the LCI.</li> </ul>

**Figure 9: ZXU1 Controller LEDs**

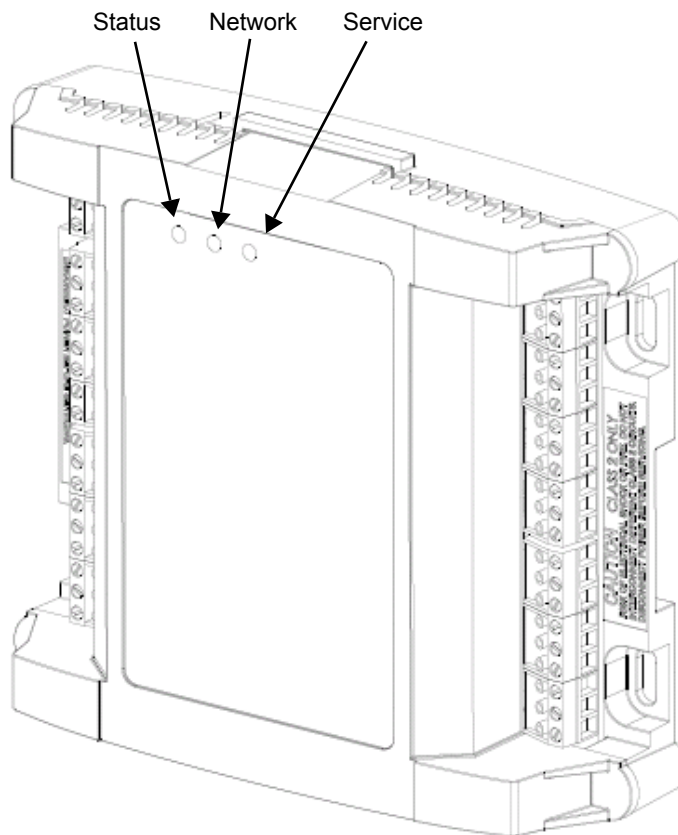

## Troubleshooting Tips

This section describes common issues and how to resolve them.

Problem	Solution
Controller is not running and Status LED is not illuminated.	No power to controller. Verify the voltage on the controller's power connector (24 VAC).
How do I reset the controller?	The controller can be reset by the LCI, or you can cycle power to the controller. Refer to the LCI documentation for more information on resetting the controller using the LCI.
The Mixing Valve will not open.	There are several reasons the mixing valve will not open, and all should be checked. <ul style="list-style-type: none"> <li>– Is there a valid Heating or Cooling demand?</li> <li>– Is the controller in an occupied mode and is the temp below or above the Unoccupied Setpoints?</li> <li>– Is the RWT below the Boiler Protection setting?</li> </ul>
The pilot relays will not come on even though the LCI indicates it is on.	Ensure that the controller and output pilot relay have been powered with 24 VAC and the output has been correctly wired to the coil of the pilot relay. Also ensure that the pilot relay has a 24 VAC coil.
The 10K thermistor reading is at its maximum or minimum.	The input is either shorted or open.
The Boiler is not being enabled when there is a demand.	Has the ZXU1 been associated to the BLM series controller? Is the controller in WWSD? If using the Heating Demand output to enable a non-networked heat source ensure it is properly wired to the heat sources demand input.
The Chiller is not being enabled when there is a demand.	Has the Cooling Demand output been properly wired to the cooling source? Ensure the wiring is correct.
Why is my RWT sensor tracking that of the associated BLM series controller?	If associated to a BLM series controller the ZXU1 will use the RWT sensor of the BLM.
Do I need to populate the OAT sensor when associating to a BLM series controller or if I have an ASM2 on the network.	No, the ZXU1 will use the OAT value of the associated BLM or networked ASM2 controller.

## Getting Help

Components within iWorX® ZXU1 controller cannot be field repaired. If there is a problem with a controller, follow the steps below before contacting your local TES representative or TES technical service.

1. Make sure controllers are connected and communicating to desired devices.
2. Record precise hardware setup indicating the following:
  - Version numbers of applications software.
  - Controller firmware version number.
  - A complete description of difficulties encountered.

**Notes:**

---

## LIMITED WARRANTY STATEMENT

Taco Electronic Solutions, Inc. (TES) will repair or replace without charge (at the company's option) any product or part which is proven defective under normal use within one (1) year from the date of start-up or one (1) year and six (6) months from date of shipment (whichever occurs first).

In order to obtain service under this warranty, it is the responsibility of the purchaser to promptly notify the local TES stocking distributor or TES in writing and promptly deliver the subject product or part, delivery prepaid, to the stocking distributor. For assistance on warranty returns, the purchaser may either contact the local TES stocking distributor or TES. If the subject product or part contains no defect as covered in this warranty, the purchaser will be billed for parts and labor charges in effect at time of factory examination and repair.

Any TES product or part not installed or operated in conformity with TES instructions or which has been subject to accident, disaster, neglect, misuse, misapplication, inadequate operating environment, repair, attempted repair, modification or alteration, or other abuse, will not be covered by this warranty.

TES products are not intended for use to support fire suppression systems, life support systems, critical care applications, commercial aviation, nuclear facilities or any other applications where product failure could lead to injury to person, loss of life, or catastrophic property damage and should not be sold for such purposes.

If in doubt as to whether a particular product is suitable for use with a TES product or part, or for any application restrictions, consult the applicable TES instruction sheets or in the U.S. contact TES at 401-942-8000 and in Canada contact Taco (Canada) Limited at 905-564-9422.

TES reserves the right to provide replacement products and parts which are substantially similar in design and functionally equivalent to the defective product or part. TES reserves the right to make changes in details of design, construction, or arrangement of materials of its products without notification.

**TES OFFERS THIS WARRANTY IN LIEU OF ALL OTHER EXPRESS WARRANTIES. ANY WARRANTY IMPLIED BY LAW INCLUDING**

**WARRANTIES OF MERCHANTABILITY OR FITNESS IS IN EFFECT ONLY FOR THE DURATION OF THE EXPRESS WARRANTY SET FORTH IN THE FIRST PARAGRAPH ABOVE.**

**THE ABOVE WARRANTIES ARE IN LIEU OF ALL OTHER WARRANTIES, EXPRESS OR STATUTORY, OR ANY OTHER WARRANTY OBLIGATION ON THE PART OF TES.**

**TES WILL NOT BE LIABLE FOR ANY SPECIAL, INCIDENTAL, INDIRECT OR CONSEQUENTIAL DAMAGES RESULTING FROM THE USE OF ITS PRODUCTS OR ANY INCIDENTAL COSTS OF REMOVING OR REPLACING DEFECTIVE PRODUCTS.**

This warranty gives the purchaser specific rights, and the purchaser may have other rights which vary from state to state. Some states do not allow limitations on how long an implied warranty lasts or on the exclusion of incidental or consequential damages, so these limitations or exclusions may not apply to you.

## CONTROLS MADE EASY®

**Taco Electronic Solutions, Inc.**, 1160 Cranston Street, Cranston, RI 02920  
Telephone: (401) 942-8000 FAX: (401) 942-2360.

**Taco (Canada), Ltd.**, 8450 Lawson Road, Unit #3, Milton, Ontario L9T 0J8.  
Telephone: 905/564-9422. FAX: 905/564-9436.

**Taco Electronic Solutions, Inc. is a subsidiary of Taco, Inc.**  
**Visit our web site at:** <http://www.taco-hvac.com>