

VPU2 Air Control – Pressure Independent Multi-Zone

SUPERSEDES: New

EFFECTIVE: August 21, 2012

Plant ID: 001-4126

PURPOSE: This guide is a consolidation of important VPU2 information that can be used when installing, commissioning and setting up the controller. It is not meant to replace any other VPU2 documents or drawings.

APPLICATION: The application is for controlling a multi-zone roof top unit, air handler or split system, and typically controls the supply static pressure by modulating a supply fan VFD. The system may also have an economizer and perform dehumidification.

IMPORTANT FACTS

- The VPU is for VAV applications and provides cooling to the associated VAV controllers.
- If an economizer is to be controlled based on dry bulb temperature, an ASM2 must be used and must have an Outside Air Temperature sensor connected.
- If an economizer is to be controlled based on enthalpy, an ASM2 must be installed and have an Outside Air Temperature and Humidity sensor connected. The VPU2 must also have a Return Air Humidity sensor connected.
- Several controllers can use the same indoor air humidity sensor for enthalpy calculations if the free cooling type is set to global humidity.
- If the fan is not being proved with a differential pressure switch or current switch, then the fan proof input must be jumpered.
- There is a 30-second delay after the fan is turned on before the flow proof input is verified.
- When the fan is turned on, there is a delay of 10 minutes before reporting a mixed air temperature alarm.
- When using staged heating or cooling, the stage time setting must be non-zero.
- When using staged heating and cooling, the stage control band must be non-zero.
- Dehumidification is accomplished by enabling the cooling cycle; there is no dehumidification enable output.
- The VPU can be associated to VAVD and VAVI controllers.

INSTALLER/ELECTRICIAN CHECKLIST

Task	Verified Yes/No
Ensure that the 24VAC power source is properly connected to terminals 38 & 39 and that the polarity is correct.	
Ensure that terminal 40 GND is connected to a known good earth ground.	
Ensure that the 3 sets of DIP switches are properly set in accordance with the drawing below, installation or application documents. The DIP switches can be accessed by removing the controllers cover. Note the black square for each position indicates the direction the switch needs to be placed.	
Ensure that the 4 sets of jumpers are properly set in accordance with the drawing and your application. The jumpers can be accessed by removing the controllers cover.	
Ensure that the proper wire is used for inputs and the communication trunk. Analog input wiring must be 18 AWG TSP (can also use multi-conductor). Taco part # Wir-018 (1 Pair + shield). Communication wiring must be Echelon approved cable 22 AWG TP. Taco part # WIR-022.	

Task	Verified Yes/No
Ensure that the shielded input wiring is properly grounded. Remember the shield must only be connected at the controller end, at the sensor end it should be cut even with the wire jacket and taped.	
Ensure that the sensors required for this application are properly installed and wired to the controller. Refer to sensor and controller installation sheets for reference.	
If the LCI is connected and powered up, press the service pin button on the VPU2 so that the controller is recognized and added to the LCI's database. This can be verified by logging into the LCI. The controller appears as Unitx_VPU2, where x is the order in which all controllers' service pin buttons have been pressed.	

COMMISSIONING THE CONTROLLER

After the VPU2 has had all inputs and outputs properly wired, a point-to-point check should be performed to ensure all terminations have been properly made. Use this checklist to verify all inputs are working correctly and reading properly in the LCI; if a point is not used, simply indicate "not used."

Steps required for verifying inputs on the VPU2

To verify the inputs and outputs, login to the LCI and perform the following steps:

1. Press **Controllers** from the Home screen.
2. Select the VPU2 from the list of controllers.
3. Press **Inputs** and verify that there are realistic temperatures. It is recommended that the temperature sensors be warmed up or cooled down so a response can be seen.
4. To verify the outputs, schedule this controller using the LCI groups.
5. Verify the VPU output has turned on in the Outputs screen.
6. Verify the physical outputs have staged on.

Inputs	Verified/initials	Outputs	Verified/initials
Fan Proof		Fan	
Static Pressure		Heat	
IAQ (Digital or Analog)		Cool	
Mixed Low Limit		Fan VFD	
Filter Status		Economizer	
Smoke Status			
Supply Air Temp			
Mixed Air Temp			
Return Air Temp			
Return Air Humidity			

CONFIGURING THE VPU2 SETTINGS

A description of VPU2 settings can be found in the Application Guide on pages 31-37. If a copy of the Application Guide is needed, it can be found at www.taco-hvac.com. Once in the web site, select the *Products* tab, and from the drop down list select *iWorx® by Taco Electronic Solutions*. A complete list of links to all documentation is shown on the left side of the web page.

TROUBLESHOOTING & TECHNICAL TIPS

Problem	Solution
Controller is not running and Status LED is not illuminated.	No power to controller. Verify the voltage on the controller's power connector (24 VAC).
How do I reset the controller?	The controller can be reset by the LCI, or you can cycle power to the controller. Refer to the LCI documentation for more information on resetting the controller using the LCI.
Can my iWorx® system contain multiple VPU2 controllers?	Yes, provided that you do not exceed the maximum number of controllers that can be handled by the Local Control Interface (LCI).
Thermistor readings fluctuate rapidly, sometimes by several degrees.	The controller is not properly grounded. The controller's ground (GND) pin (T40) must be connected to earth ground. Also ensure that the controller's digital inputs are dry contacts and that no voltage is being applied or switched to the inputs.
How do I associate my VAVI controllers with the VPU2?	Use the VPU2's grouping mechanism, specifically Zone Members on the <i>HVAC Setup</i> screen of the LCI.

TYPICAL VPU2 WIRING

Rooftop Unit with Pressure Independent Terminal Boxes Power Sourced 'Rooftop Unit'

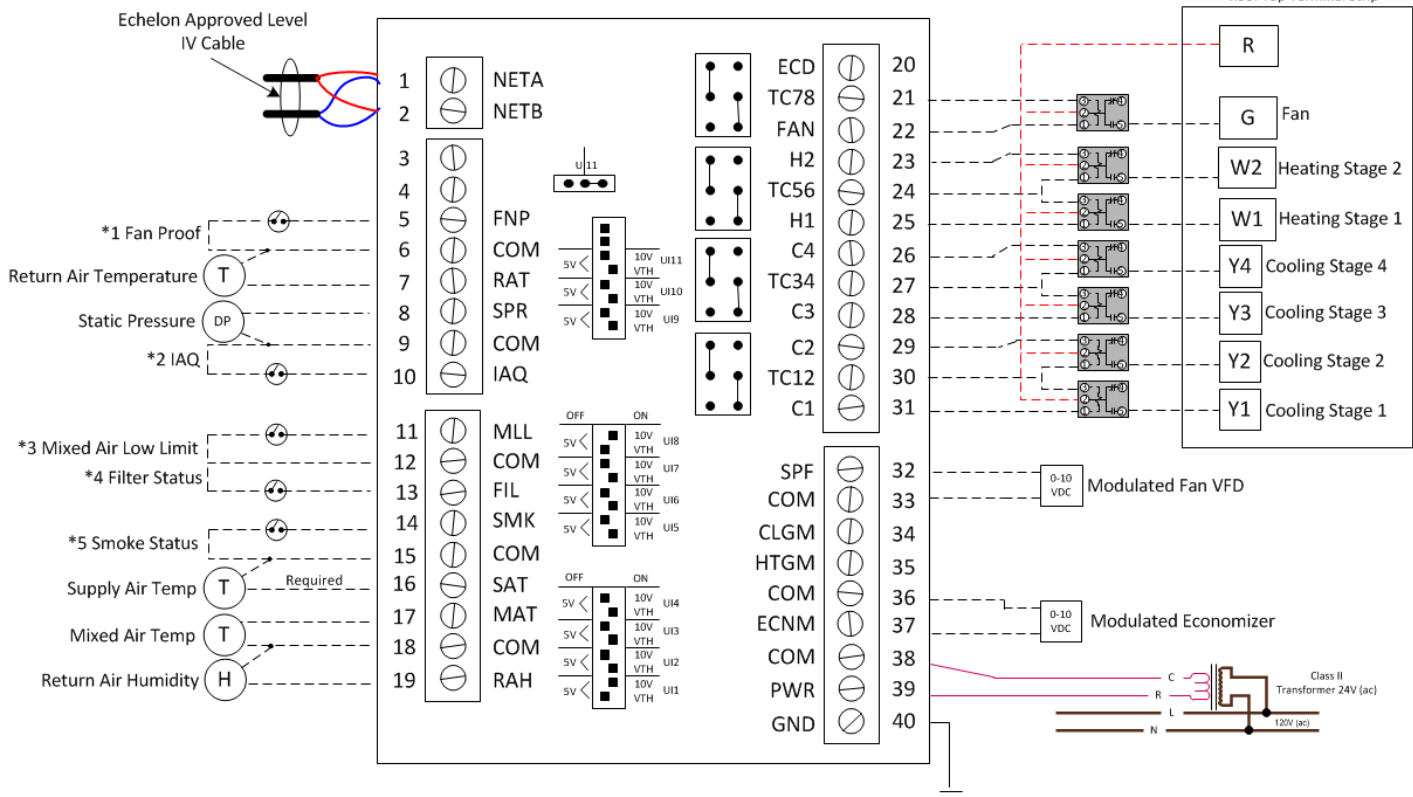

- *1-Must be a normally open fan proving switch, jump out if not used.
- *2-Can be a 0-10vdc device. Dip switches must be properly configured
- *2,3,4,5-Must be a normally open switch/device. Do not jump if not used

Symbols

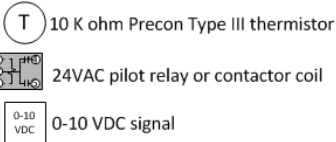

Output Jumper Positions

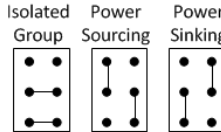

Dip Switch Positions

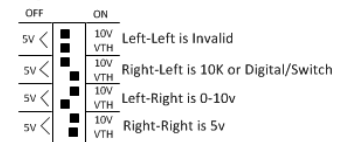

CONTROLS MADE EASY®

Taco Electronic Solutions, Inc., 1160 Cranston Street, Cranston, RI 02920
Telephone: (401) 942-8000 FAX: (401) 942-2360.

Taco (Canada), Ltd., 8450 Lawson Road, Unit #3, Milton, Ontario L9T 0J8.
Telephone: 905/564-9422. FAX: 905/564-9436.

Taco Electronic Solutions, Inc. is a subsidiary of Taco, Inc.
Visit our web site at: <http://www.taco-hvac.com>