

## BZU3 Hydronic Zoning Control

SUPERSEDES: New

EFFECTIVE: August 21, 2012

Plant ID: 001-4114

**PURPOSE:** This guide is a consolidation of important BZU3 information that can be used when installing, commissioning and setting up the controller. It is not meant to replace any other BZU3 documents or drawings.

**APPLICATION:** The application is for controlling up to 4 hydronic heating zones.

### IMPORTANT FACTS

- Any unused inputs should either be shorted or have a 10K ohm resistor placed across them. If the input is not shorted or connected by a 10K resistor, that zone creates no demand on the associated boiler or the demand output.
- TS100 & TS200 series thermostats or Precon type II or type III sensors may be used for temperature measurement inputs.
- The high and low temperature alarm limits are adjustable.
- The Heat Demand output would typically be connected to TT of a non-networked boiler or a manifold pump or valve.

### INSTALLER/ELECTRICIAN CHECKLIST

Task	Verified Yes/No
Ensure that the 24VAC power source is properly connected to terminals 38 & 39 and that the polarity is correct.	
Ensure that terminal 40 GND is connected to a known good earth ground.	
Ensure that the 3 sets of DIP switches are properly set in accordance with the drawing below, installation or application documents. The DIP switches can be accessed by removing the controllers cover. Note the black square for each position indicates the direction the switch needs to be placed.	
Ensure that the 4 sets of jumpers are properly set in accordance with the drawing and your application. The jumpers can be accessed by removing the controllers cover.	
Ensure that the proper wire is used for inputs and the communication trunk. Analog input wiring must be 18 AWG TSP (can also use multi-conductor). Taco part # Wir-018 (1 Pair + shield). Communication wiring must be Echelon approved cable 22 AWG TP. Taco part # WIR-022.	
Ensure that the shielded input wiring is properly grounded. Remember the shield must only be connected at the controller end, at the sensor end it should be cut even with the wire jacket and taped.	
Ensure that the sensors required for this application are properly installed and wired to the controller. Refer to sensor and controller installation sheets for reference.	
If the LCI is connected and powered up, depress the service pin button so that the controller is recognized and added to the LCI's database. This can be verified by logging into the LCI and depressing the Controllers button. The controller appears as Unitx_BZU3, where x is the order in which all controllers' service pin buttons have been pressed.	

## COMMISSIONING THE CONTROLLER

After the BZU3 has had all inputs and outputs properly wired, a point-to-point check should be performed to ensure all terminations have been properly made. Use this checklist to verify all inputs are working correctly and reading properly in the LCI; if a point is not used, simply indicate “not used.”

### Steps required for verifying inputs on the BZU3

To verify the inputs and outputs, login to the LCI and perform the following steps:

1. Press **Controllers** button from the Home screen.
2. Select the BZU3 from the list of controllers.
3. Press **Inputs** and verify that there are realistic temperature readings. It is recommended that the temperature sensors be warmed up or cooled down so a response is seen. To verify digital inputs, change the state of the sensor to see a response.
4. To verify the outputs, press **All Settings**.
5. From the list of settings, select **Zone x Settings** and set Zone Ovrld to “Yes.”
6. Verify the output has turned on in the Outputs screen.
7. Verify the physical pump has turned on.
8. After verification, set Zone Ovrld to “No.”

Inputs	Verified/initials	Outputs	Verified/initials
Zone 1 Air Temp		Heating Zone 1	
Zone 1 Floor Temp		Heating Zone 2	
Zone 2 Air Temp		Heating Zone 3	
Zone 2 Floor Temp		Heating Zone 4	
Zone 3 Air Temp		Heating Demand	
Zone 3 Floor Temp		Primary Pump	
Zone 4 Air Temp		Group 1 Circulator	
Zone 4 Floor Temp		Group 2 Circulator	
Outside Temp		Modulating Zone 1	
		Modulating Zone 2	
		Modulating Zone 3	

## CONFIGURING THE BZU3 SETTINGS

A description of BZU3 settings can be found in the Application Guide starting on page 21. If a copy of the Application Guide is needed, it can be found at [www.taco-hvac.com](http://www.taco-hvac.com). Once in the web site, select the *Products* tab, and from the drop down list select *iWorx® by Taco Electronic Solutions*. A complete list of links to all documentation is shown on the left side of the web page.

## TROUBLESHOOTING & TECHNICAL TIPS

Problem	Solution
Controller is not running and Status LED is not illuminated.	No power to controller. Verify the voltage on the controller's power connector (24 VAC).
How do I reset the controller?	The controller can be reset by the LCI, or you can cycle power to the controller. Refer to the LCI documentation for more information on resetting the controller using the LCI.
A zone pilot relay will not come on even though the LCI indicates it is on.	Ensure that the controller and output pilot relay have been powered with 24 VAC and the output has been correctly wired to the coil of the pilot relay. Also ensure that the pilot relay has a 24 VAC coil. Ensure that the output jumpers are in the right position for this application (isolated group, power sourcing or power sinking).
The 10K thermistor reading is out of range.	The input is either shorted or open, or the dip switches are not set. Make sure the appropriate dip switch for this input is in the VTH "On" and 5V "Off" position.
Thermistor readings fluctuate rapidly, sometimes by several degrees.	The controller is not properly grounded. The controller's ground (GND) pin (T40) must be connected to earth ground. Also ensure that the controller's digital inputs are dry contacts and that no voltage is being applied or switched to the inputs.
Controller is not running and Status LED is not illuminated.	No power to controller. Verify the voltage on the controller's power connector (24 VAC).
Why is my pump short cycling?	Ensure that the temperatures are properly grounded and that the PI Parameters are set properly. Kp should be between 5-10% and Ki should be set between 5-10Min.
Why is my space cold in the morning? The setpoint is at 70 °F but the room is still at the Unoccupied Temperature.	When a radiant zone enters the occupied mode after a night setback, the room needs to heat up and this takes longer than a conventional forced air heating. To avoid situations like that, schedule your occupied time 30 min (or the desired warm-up time for your individual situation) before you get up or expect the temperature to have reached the comfort point.
What should I do with unused inputs?	Any unused inputs should either be shorted or have a 10K ohm resistor placed across them. If the input is not shorted or does not have a 10K resistor across it then that zone creates no demand on the associated boiler and the demand output.

# TYPICAL BZU3 WIRING

## Typical BZU3 Power Sourcing

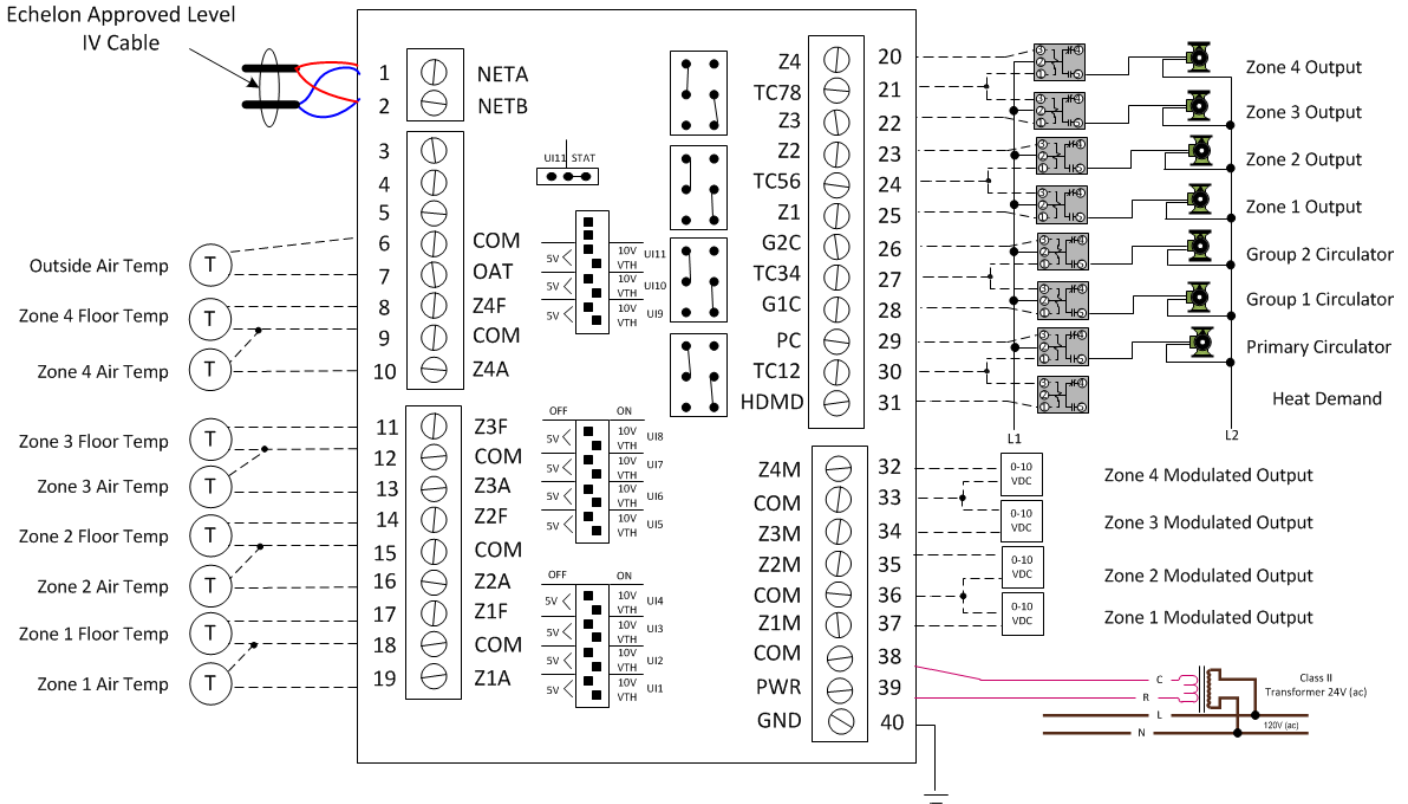

### Symbols

- 10 K ohm Precon Type III thermistor
- 24VAC pilot relay or contactor coil
- 0-10 VDC signal

### Output Jumper Positions

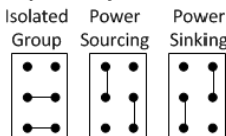

### Dip Switch Positions

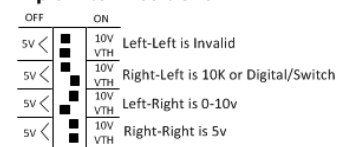

## CONTROLS MADE EASY®

**Taco Electronic Solutions, Inc.**, 1160 Cranston Street, Cranston, RI 02920  
 Telephone: (401) 942-8000 FAX: (401) 942-2360.

**Taco (Canada), Ltd.**, 8450 Lawson Road, Unit #3, Milton, Ontario L9T 0J8.  
 Telephone: 905/564-9422. FAX: 905/564-9436.

**Taco Electronic Solutions, Inc. is a subsidiary of Taco, Inc.**  
 Visit our web site at: <http://www.taco-hvac.com>